

GreenLife

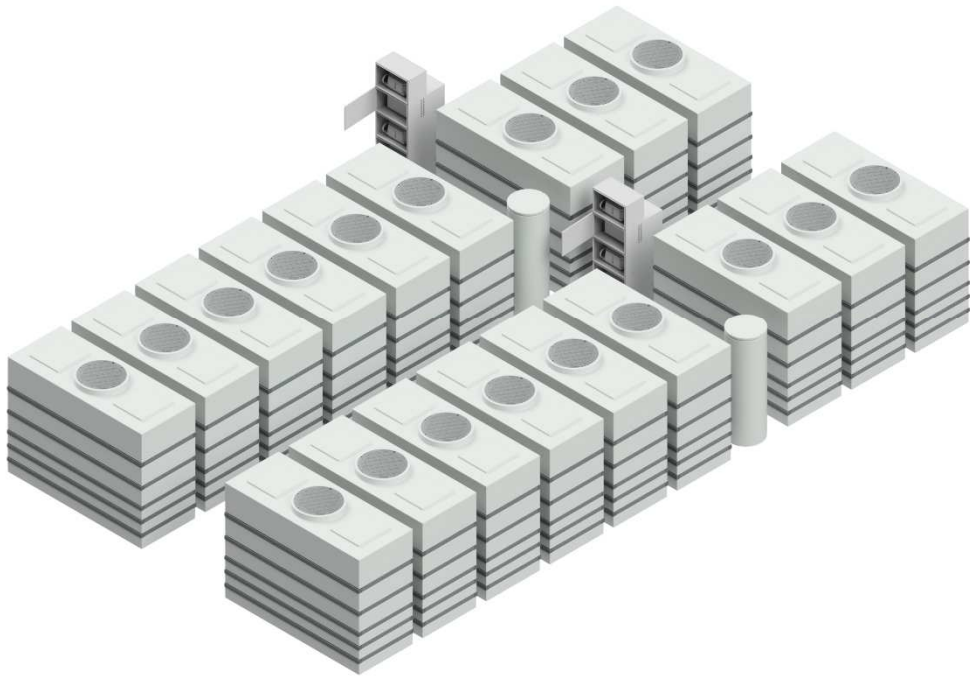

Installation, Commissioning and Maintenance Instructions GWI 50.2 – 50.000



GreenLife GmbH
Sacktannen 1a
D-19057 Schwerin

Dear Customer,

Congratulations on your purchase of this GreenLife product and thank you for the confidence you have placed in us.

Please check the goods for any damage when you receive them.

The carrier, not the manufacturer or the supplier, is liable for transport damage. Transport damage reported after receipt of the goods can no longer be claimed. If the packaging is damaged, the goods must be unpacked immediately in the presence of the supplier in order to determine any damage, which must be reported to the carrier in writing. The goods must remain with the buyer until the transport damage has been clarified.

Before installing, connecting and/or operating this product, it is essential to read the installation and maintenance instructions carefully and completely and to observe all safety instructions. Please keep these instructions in a safe place for future reference.

If you have any questions or comments, please do not hesitate to contact us at

service@greenlife.de

at any time.

Kind regards

Your GreenLife Team

Contents

- 1. Introduction..... 3
- 2. Safety and Protection 3
 - 2.1 Electrical installations 3
 - 2.2 Inadmissible modes of operation 3
- 3. Product description..... 4
 - 3.1 General..... 4
 - 3.2 Function and Control..... 4
 - 3.3 Operation parameters 5
 - 3.4 System description 5
 - 3.5 Use 6
- 4. Control 8
 - 4.1 Description of the control cabinet..... 8
 - 4.2 Description of the control 8
 - 4.2.1 Operation (operator level) 9
 - 4.3 Important note on the service functions 10
 - 4.4 Service work..... 10
 - 4.4.1 Safety during service work..... 10
- 5. Commissioning and continuous operation 11
 - 5.1 Commissioning..... 11
 - 5.1.1 Prerequisites for commissioning 11
 - 5.2 Initial commissioning 11
 - 5.2.1 Handover 12
 - 5.3 Continuous operation (disposal instructions) 13
- 6. Maintenance 15
 - 6.1 Self-checks of the operator 15
 - 6.2 Maintenance by qualified personnel 16
- 7. Commissioning report Greywater Recycling Plant..... 18

1. Introduction

The greywater recycling plant, hereinafter referred to as GWR plant, is used exclusively for the treatment and reuse of slightly contaminated wastewater (greywater) from showers, wash hand basins and bathtubs, which can preferably be used for flushing toilets and washing machines, but is also suitable for garden sprinkling and cleaning purposes.

When operated properly, the treated greywater achieves the quality required by the EU Bathing Water Directive.

In single households, users are free to wash their laundry with treated greywater. In an apartment building, service water can be offered for washing laundry. Alternatively, the resident must be provided with a drinking water connection for the washing machine. As a rule, the operator must notify the competent health authority of service water utilization systems by means of a form. This form, together with a commissioning report and an inspection plan, is an integral part of these instructions for use.

Any other use is considered improper. The manufacturer and/or seller are not liable for any damage resulting from this!

2. Safety and Protection

2.1 Electrical installations



Your electrical installations must comply with the general installation regulations. The electrical mains (230V~/50Hz AC) to which the system is connected must have a residual current device (RCD) with a 30 mA fuse. Please contact your specialist electrical company, as the electrical connection of the system must be permanently installed. Operation or connection via a safety plug is not permitted.

2.2 Inadmissible modes of operation



The limit values specified in the technical data must not be exceeded under any circumstances. The clear water obtained from the unit must not enter the mains supply for drinking water. It must also not be used as drinking water. The unit must not be operated with organically highly contaminated kitchen wastewater, aggressive wastewater (concentrated acids/alkalis), wastewater containing faeces, medical sludge baths and highly foaming wastewater. For highly contaminated wastewater from toilets, kitchen drains or washing machines, the quality targets of the treatment are not achieved and damage to the system (membrane) cannot be ruled out. The supply of strongly alkaline cleaning agents (chlorine cleaners, etc.), dispersion paints, varnishes, hair dyes, oils and greases also impairs the performance of the membrane and the quality of the clear water and must be excluded. Grease and oil in particular can irreversibly damage the membrane.

3. Product description

3.1 General



The system must be installed and operated in accordance with the relevant state of the art, in particular technical regulations such as DIN 1988 T1 to T8, DIN 1986, DIN EN 1717, DIN 2403, TrinkwV 2001, must be taken into account. The limit values specified in the technical data must not be exceeded under any circumstances. The greywater brought into the system must be collected using separate pipes. These must be clearly marked. The clear water obtained from the system must be distributed through separate, clearly marked pipes and tapping points. It must not enter the mains supply for drinking water. It must also not be used as drinking water. Suitable uses are toilet flushing and irrigation. The system must not be operated with organically highly contaminated kitchen wastewater, aggressive wastewater (concentrated acids/ alkalis), wastewater containing faeces, medical sludge baths and highly foaming wastewater.

3.2 Function and Control

The GWR plant consists of several tanks: sedimentation, aeration, filtration and service water tanks.



The pressure boosting system is not described in this manual. Please read the corresponding instructions.

The incoming greywater is pre-filtered and collected in the sedimentation tank and forwarded for biological treatment. Solids and bacteria are separated via the membrane filter and the filtrate is stored in the service water tank. The service water network is supplied from the service water tank by means of the pressure boosting system. If the availability of service water falls short, drinking water must be replenished in accordance with the standards or rainwater must be replenished, thus ensuring security of supply.

By using a filtrate shaft, the filtrate from this can be lifted into the service water tank. This makes it possible to position the filtration tank and the service water tank independently of each other. The filtrate should not be lifted higher than 1.0 m above the minimum water level in the grey water tank. Lifting into an external service water tank is also possible.

The greywater treatment and filtration are controlled automatically.



Exceptions and special cases

Power failure: After a power failure, the system automatically returns to normal operation.

Absence: When there is no greywater supply, e.g., during absence, the system should remain switched on in order to maintain ventilation. Drinking water feed and water feed pumps can be switched off.

3.3 Operation parameters

The following operating parameters apply:

sedimentation tank:	8,000 l
aeration tank:	32,000 l
filtration tank:	16,000 l
filtration shaft:	700 l
service water tank:	16,000 l
pollution load in the influent:	maximum 50g BSB5 / d
rated voltage:	230 V / 50 Hz
rated Power:	8,000 W (without pressure boosting system)

3.4 System description

Figure 1 shows the GWI 50.2 - 50.000 system

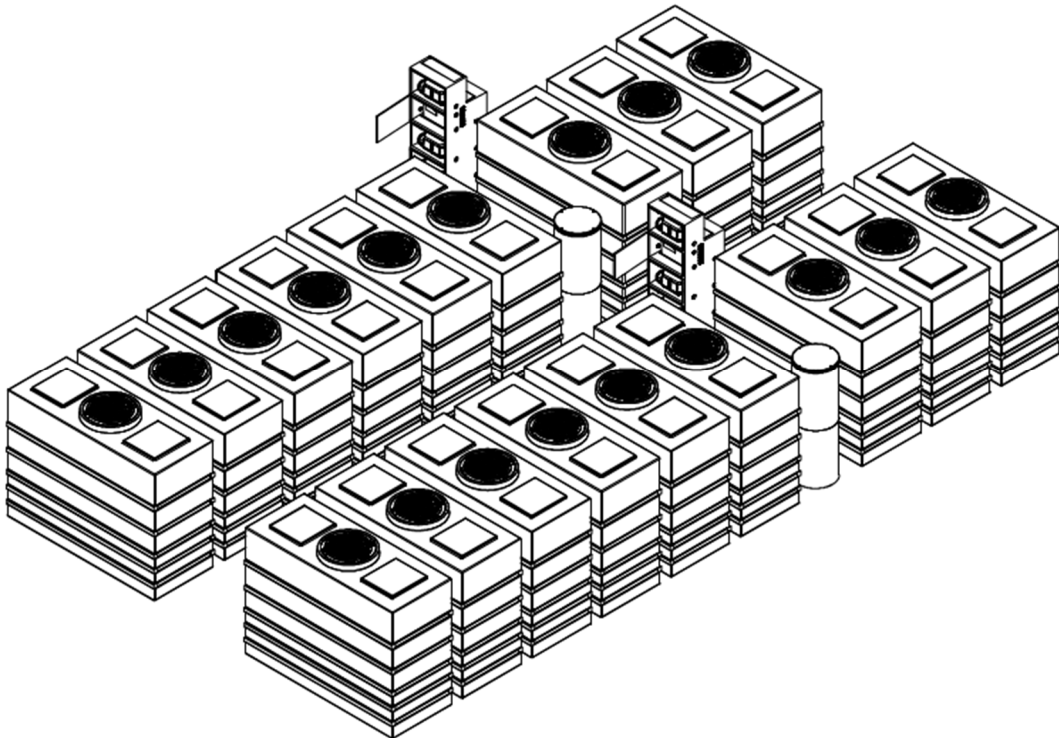

Figure 1: Greywater-Recycling-Plant GWI 50.2 – 50.000

sedimentation tank

- greywater inlet
- overflow (immersion pipe at the top) to the aeration tank
- overflow to the sewer
- air exchange to the aeration tank

aeration tank

- removal of aeration water via submersible pressure pump with floating switch
- air connection for aeration pumps for the aerator plates
- overflow to the sewer
- air exchange to sedimentation and filtration

filtration tanks

- air connection aeration pumps for the membrane filter modules
- membrane filter modules
- floating switch
- overflow to the sewer
- air exchange to aeration tank

filtrate shaft

- filtrate pump and controlled solenoid valve
- service water extraction via submersible pressure pump with floating switch

service water tanks

- connection for pressure boosting system
- floating switch
- overflow to the sewer
- mains water back-up

control cabinet

- control module with display
- aeration pumps

3.5 Use

The GreenLife Greywater-Recycling systems are designed and constructed for the purification of domestic greywater. The connected loads and cleaning capacities depend on the quality of the greywater supplied.



Any other or further use of the system or its components is considered improper.

The instructions contained in the operating manual must be observed.

The system can only be used for its intended purpose if maintenance is carried out and documented in accordance with the instructions in this manual.

The manufacturer accepts no liability for damage caused by failure to observe the operating instructions or by improper use.

Incorrect discharges (domestic wastewater, chemicals, pesticides etc.) can lead to a malfunction of the system and the biological degradation process (e.g. overloading or poisoning). This leads to an impairment of the purification performance of the system.

The discharge of the following substances is not permitted:



- domestic waste water
- greywater from kitchen and laundry
- substances that can impair the biodegradation process (chemicals, pesticides) or are not biodegradable.
- solid or foreign substances that can impair the mechanical components of the system.

Wastewater quantities or pollutant loads that do not correspond to the design data and lead to a hydraulic overload or to an overload of the degradation capacity of the plant represent improper use and are not permissible!

It is imperative that you follow the instructions in table 1 on which substances must not be fed into the system!

The treated greywater (clear water / process water / service water) can be used for toilet flushing, cleaning or garden irrigation.

It is not recommended to use the clear water for washing clothes. Reason: If substances are added that do not correspond to the intended use of the system, e.g. hair dye, etc., there is a possibility that these colour pigments will get into the clear water. The treated greywater (clear water / process water / service water) can be used for toilet flushing, cleaning or garden irrigation.

It is not recommended to use the clear water for washing clothes. Reason: If substances are added that do not correspond to the intended use of the system, e.g. hair dyes, etc., there is a possibility that these Operation (operator level) colour pigments will get into the clear water.

4. Control

4.1 Description of the control cabinet

The control cabinet houses the control cabinet with display, the aerator pump and wiring and is pre-assembled ready to plug in.

The control cabinet is fixed to the wall with a stainless-steel mounting bracket. This is mounted with rubber buffers. This provides better sound insulation. Stainless steel mounting bracket and fixing material are included in the scope of delivery.

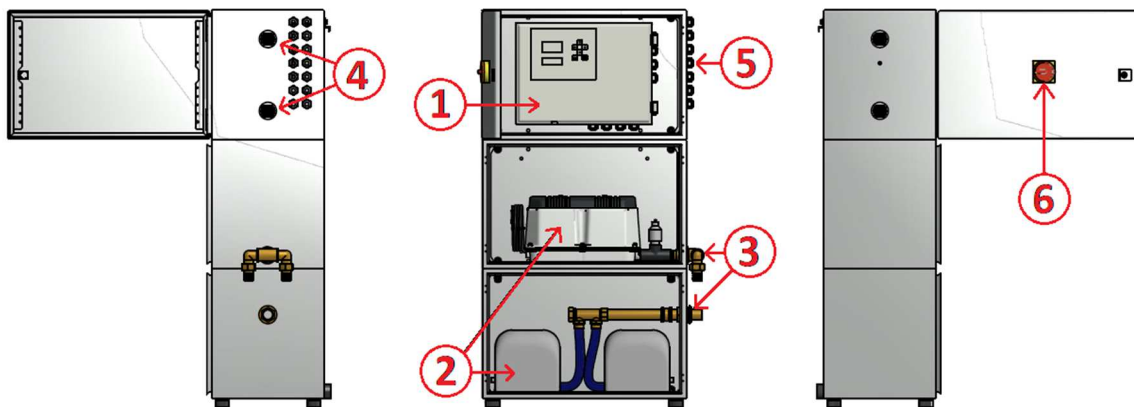

Figure 2: Control cabinet (variable)

1. control with display and operating element
2. aerator pumps
3. ventilation ducts
4. ventilation of switch cabinet via grille
5. feed-through for control cables, float switch, feed pumps
6. emergency stop main switch

4.2 Description of the control

The control system has been specially designed for the GreenLife greywater recycling plant. It controls all processes in the GWR plant fully automatically.

In the event of a power failure, the control programme and the counted operating hours are retained in the internal memory. After the power supply is restored, the system restarts automatically.

The module contains the actual intelligence and a power reserve of approx. 480 hours. All digital inputs and outputs are also located here. Furthermore, there are cable glands for the float switches of individual tanks, as well as cable glands for the feed pumps.

All cable glands are colour-coded and must not be confused in order to ensure smooth operation.

The control unit is powered centrally with 230V 50Hz.

4.2.1 Operation (operator level)

Normal operation is fully automatic and independent of the operator. A toggle indicator appears in the display. The display shows the current operating status. In addition, times and other states are displayed.

The operating and display elements of the module are shown in Figure 3.

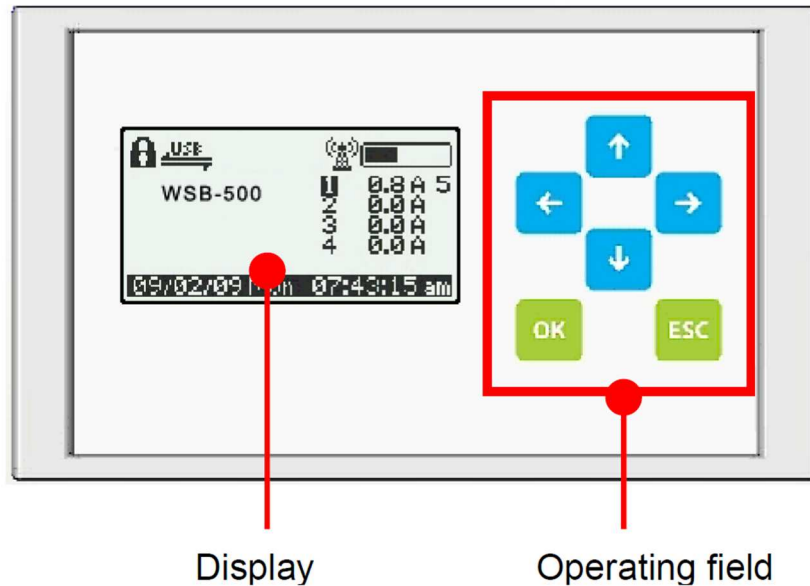
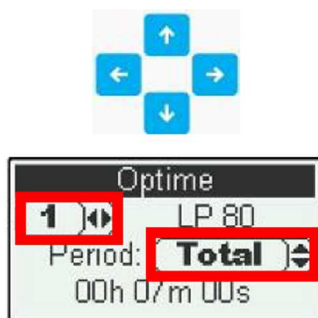
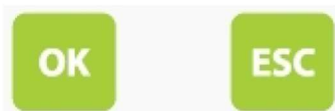

Figure 3: Control Unit Serie 2.5



Changes in the display can be made at the displayed position using the arrow keys in the control panel.



Settings and the selection of menu items can be confirmed with the OK key.

To delete changes or to exit the respective menu, press the ESC key.

Figure 4: Display and operation Serie 2.5

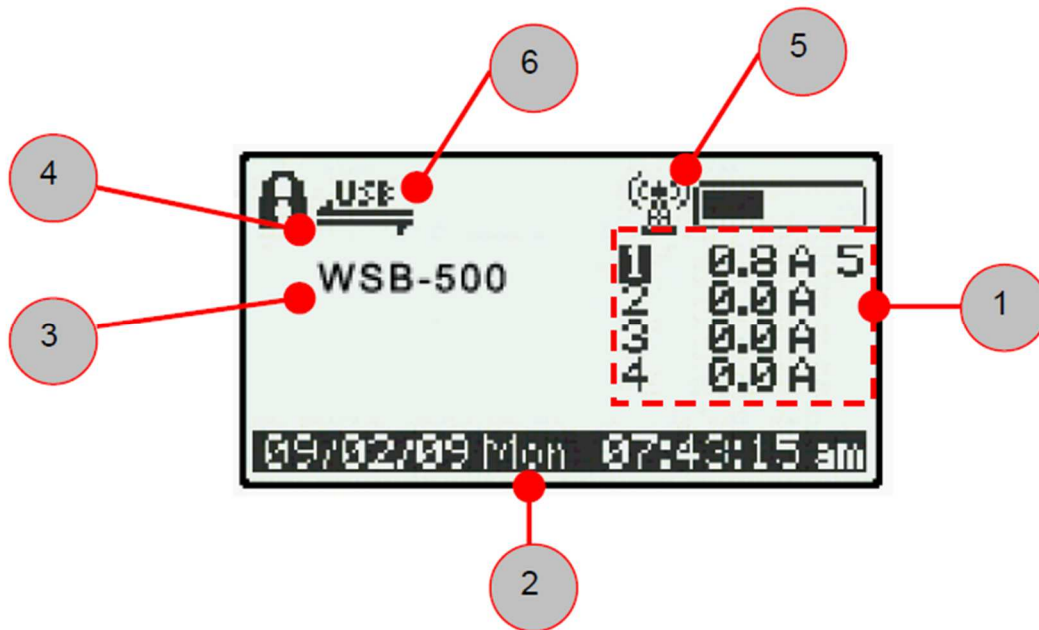

Figure 5: Display Serie 2.5

- 1 Status display of the outputs; display of the current power consumption of the system(s).
- 2 Display of the system time and date
- 3 Display of the operating mode
- 4 Display when the service menu is locked
- 5 Display of GSM status with signal strength
- 6 Display when the control unit is connected to the USB

4.3 Important note on the service functions



Warning

All the points described below can have a considerable influence on the functioning of the system and are reserved for the specialist company for installation, commissioning and maintenance.

Unauthorised operating errors can result in the discharge values not being complied with or warranty claims or claims for damages against the manufacturer or supplier becoming invalid.

4.4 Service work

4.4.1 Safety during service work



Danger

Service work on the control cabinet may only be carried out by qualified electricians!

Before starting installation work, disconnect the cabinet from the mains and secure it against being switched on again!

Before opening the housing, disconnect the system from the mains and secure it against being switched on again!

5. Commissioning and continuous operation

5.1 Commissioning

5.1.1 Prerequisites for commissioning

In the case of a new building or renovation of a building, the GWR system must not be put into operation until the construction work on the building has been completed. Furthermore, it must be ruled out that substances produced during construction work on the building or on the sanitary facilities enter the system. Paints, lacquers, alkalis, grease or similar substances can clog or otherwise damage the GWR system, as already described.

Before commissioning, check whether the following requirements are met.



Danger

- The use of the system is in accordance with its intended use and is carried out in accordance with the design
- All installation work is completed according to the operating instructions
- The tank(s) of the system are completely filled with fresh water.

It has been checked and ensured that there is no danger from the system during commissioning.

Commissioning is carried out by a competent person who is familiar with the functioning of the entire system and the contents of the operating instructions.



Warning

In the delivery state, the basic setting of the control unit is set to the respective system size and is shown in the display.

5.2 Initial commissioning



Danger

The control cabinet has a separate mains switch (residual current circuit breaker) and starts automatic operation as soon as it is connected to the mains and switched on!

Cabinets can start up / be switched on abruptly!

Before putting the system into operation for the first time by plugging in the mains plug of the board control, it must be ensured that:

- Commissioning is carried out by competent persons who are familiar with the functioning of the entire system and the contents of the operating and maintenance instructions.
- all prerequisites for commissioning listed in ⇒ chapter 5.1.1 are fulfilled
- there is no danger from the system!
- The service water tank is filled with 20 cm of water so that the drinking water feed does not start automatically.
- The system is connected to the prepared installations.

For initial commissioning, the mains plug is plugged in and the system is switched on at the mains switch.

The system now goes into the respective mode that is programmed. Depending on the duration of storage and delivery of the cabinet, the date and time may have to be set again.

Now check whether ventilation is taking place in the containers. The display of the control cabinet shows which process is currently taking place.

Ready for use mode

The GWR system is in stand-by mode. In this phase, either sufficient service water is treated or not enough greywater is available for recycling. In this mode, the aeration tank is aerated at regular intervals. The bubble pattern should be strong and uniform.

Aeration mode

During aeration, the aeration tank and the filtration tank are aerated at regular intervals. The bubble pattern should be strong and uniform.

Lifter mode

The siphon pump lifts the activated greywater into the filtration tank. The filtration tank is aerated during this phase. The bubble pattern should be strong and uniform.

Filtration phase mode

The filtrate pump delivers the filtered service water into the service water tank. At the same time, air flows over the pipe and beads upwards over the filter surfaces. In this phase, the Aeration tank is also revitalised and aerated. The bubble pattern should be strong and uniform. If no or too little air arrives at the filter, disconnect the system from the power supply and check the aerator hose.



Warning

In the delivery state, the basic setting of the control system is set to the respective system size.

5.2.1 Handover

After completion of installation and commissioning, the operator of the system must be instructed by the installer. This must be documented and a commissioning report drawn up (⇒ Chapter 7) and signed by the operator and installer. The system must be handed over to the operator together with the instructions, Parts 1 and 2. The operator must ensure annual maintenance.

5.3 Continuous operation (disposal instructions)

For compliance with the cleaning requirements, operation must be in accordance with the operating instructions.



The greywater system must be permanently ready for operation (= trouble-free on the mains)!

Operation is only permissible if the greywater supplied corresponds to the design data in terms of quantity and quality.

In principle, only substances that correspond to the characteristics of domestic greywater may be fed into the greywater system.

Biocides, toxic substances or biologically incompatible or degradable substances must not enter the system, as they lead to biological process problems (⇒ Table 1: Disposal instructions).

Liquids and solids that can lead to clogging of pipes or damage to aggregates must not be discharged (⇒ Table 1: forbidden substances).

Table 1: forbidden substanceses

Substances that must not enter the system	Caused problem	Correct disposal point
Ash	does not decompose	waste bin (residual waste)
Solids , e.g.: Sanitary towels, ear swabs, plasters, panty liners, tampons, textiles	poison the greywater, eat away at pipelines, affect the quality of process water	waste bin (residual waste)
Liquids , e.g.: Nail varnish, nail varnish remover, cream, make-up remover, hair dye, bleach.	poison the greywater, eat away at pipelines, affect the quality of process water	collection points
Medicines/Drugs	poison the greywater, affect the quality of process water	collection points, pharmacies
Cleaning agents , e.g.: Disinfectants, cleaning agents (pipe cleaners), thinners, brush cleaners.	poison the greywater, eat away at pipelines, affect the quality of process water	collection points
Fixed Binders , e.g.: Cat litter, bird sand	lead to deposits and blockages	waste bin (residual waste)
Liquids according craft activities e.g.: Chemicals, paints, varnishes, oils, soldering water, cement water, wallpaper paste	poison the greywater, eat away at pipelines, affect the quality of process water	collection points
Kitchen waste , e.g.: Grease, oil, food waste	lead to deposits and blockages, attract vermin	Waste bin (organic waste), collection points
Machine lubricants , substances containing lubricants	poison the greywater, affect the quality of process water	collection points
Pesticides , e.g.: Plant protection products, pesticides	poison the greywater, affect the quality of process water	collection points

6. Maintenance

6.1 Self-checks of the operator

The operator of a GWR plant has the duty to ensure a smooth operation of the plant.

Therefore, the regular inspections are of great importance.

All maintenance, inspections or other work on the GWR system must be recorded in detail in the operating logbook.

The operator of the GWR system must have the work carried out by a competent person appointed by him if he does not have the necessary expertise¹ himself. When commissioning the system, the operator must be instructed by a competent person. The instruction shall be certified.

The operator or an authorised person must carry out the functional checks and work listed below and pump out the sludge at the specified intervals.



Warning

Any defects or faults detected must be rectified immediately by the operator or by an authorised specialist!

Daily controls

Check whether the system is operating properly. This is the case when the basic display appears in the control cabinet display and there is no fault message. The unobstructed air supply to the control cabinet must be guaranteed. There must be a uniform bubble pattern in the aeration and filter tank.

Monthly checks

- Read off the operating hours and enter the values in the operating logbook.
- Visual inspection of all system parts (feed pumps, hoses, covers, replenishment, etc.)
- Visual inspection of all tanks
- Visual inspection of the bubble pattern in the aeration and filter tank
- Visual inspection of service water
- Visual inspection of all inlets and outlets for blockages
- (if available: visual inspection of UV system, lamps)

¹ *Competent" is defined as persons of the operator or appointed third parties who, due to their training, knowledge and experience gained from their practical work, ensure that they carry out self-monitoring of greywater recycling facilities properly.*

6.2 Maintenance by qualified personnel



Danger

All system parts that require regular maintenance must be safely accessible at all times. Maintenance must be carried out at least once a year (at intervals of approx. 12 months) or as required.



Warning

Observe occupational health and safety and hygiene regulations!

If it is necessary to enter the greywater system for repair or maintenance purposes, special care must be taken.

During maintenance work, the relevant accident prevention regulations must be observed.

When servicing the electrical units (e.g. booster system, aerator pump), the manufacturer's maintenance intervals must be observed.

The maintenance carried out is to be noted in the operating logbook, manual part 1.

Maintenance content

- Inspection of the operating diary with analysis of regular operation
- Reading out and entering the operating hours
- Inspection of all tanks
- Inspection of all connections and joints
- Check of all valves
- Checking of all aerator pumps (see manufacturer's instructions)
- Checking all float switches
- Carrying out general cleaning work, e.g. removal of deposits or foreign bodies
- All tanks:
 - Check water visually
 - Check odour
 - Clean tank
- Record any component changes in writing in the operating manual
- Functional check of the important mechanical, electrotechnical and other plant components, in particular of the feed pumps and the air compressor.
- Maintenance of the aerator pump according to the manufacturer's instructions.
- Maintenance of the UV system and the lamp according to the manufacturer's instructions.
- Checking the structural condition of the system. Here e.g.:
 - Accessibility
 - Corrosion damage
 - correct fit of tank covers
- Checking that ventilation is adequate.

- The findings and work carried out must be documented in a maintenance report and handed over to the operator. The operator must add the maintenance report to the operating manual.

7. Commissioning report Greywater Recycling Plant

Installation company		Plant location	
Company:		Customer (operator)	
Street, Nr.:		Street, Nr.	
ZIP, City:		ZIP, City	
Represented by (installer):		Actual number of persons connected to the system	
Details of technical equipment			
Designation of plant			
Serial number of control	(if available)		
Designation of air compressor			
Motor power of air compressor			
Details of tank geometry			
Plant type			
Number of tanks			
Software version			
Special features			
Details of work carried out and handover of the system to the operator			
Result waterproof test		O.K.	not O.K.
Filling of the complete system		yes	no
Installed according to installation manual		yes	no
Control set		yes	no
Checking the bubble pattern		O.K.	not O.K.
Commissioning of the plant		done	not done
Briefing of the operator		done	not done
Operating and maintenance instructions incl. operating diary handed over		yes	no
<p>The operator undertakes to remedy previously listed defects (if applicable). The operator has been informed of his duties of care and instructed in the inspection and maintenance work to be carried out by him.</p>			
Installer	<i>Place, date, company stamp</i>	Customer / Operator	

Please copy the protocol and send one copy each to the operator, the installing company and the manufacturer. GreenLife GmbH, Sacktannen 1a, D-19057 Schwerin